



V-rings

know-how makes the difference

ERIKS



VALVES AND INSTRUMENTATION



T +31 72 514 18 00
E valves@eriks.nl

globe valves
gate valves
check valves
strainers
sight glasses
steam traps
reducing valves
safety valves
gauge glasses
overflow valves
vacuum and air relieve valves
ball valves
butterfly valves
pneumatic and electric actuators
diaphragm valves
pinch valves
measurement and regulation components for:

- pressure
- temperature
- flow
- level

control valves
solenoid valves

PLASTIC PIPING



T +31 72 514 18 11
E piping@eriks.nl

pipes and fittings of:

- Superflo ABS
- Air-Line Xtra
- PE
- PP
- PVC
- PVC-C
- PVDF

ball valves
diaphragm valves
butterfly valves
globe valves
check valves
strainers
overflow valves
reducing valves
solenoid valves
clamps
tools
cements
plastic tanks
wall sleeves
repair clamps

HOSES, ACCESSORIES AND EXPANSION JOINTS



T +31 72 514 18 22
E hoses@eriks.nl

hoses of:

- rubber
- plastic
- PTFE
- metal

hose couplings
coupling systems
hose clamps
hose reels
hose reel carts
hydraulic hoses
fittings and couplings for hydraulic expansion joints of:

- rubber
- metal
- fabric
- PTFE

INDUSTRIAL PLASTICS



T +31 72 514 18 33
E plastics@eriks.nl

semi-manufactured and finished products of:

Eriflon-PTFE - PVDF - PCTFE
Ertalon - PA6 and PA66
Ertacetal - POM
Ertalyte - PETP
Nylatron
Fluorosint
Torlon
Techtron
PEEK/PSU/PEI
Merlin-PI
Trovidur/Epradur PVC
Multilene PE and PP
polycarbonate
acrylate - PMMA - PET
Epratex/Tufnol-PF (lami-nated fabric)
Haga - PF (laminated paper)
RX[®] Grate/GVK (glass-fibre reinforced plastics)
Erlan/Rhino Hyde[®]-PUR

FLANGE GASKETS



T +31 72 514 18 44
E seals@eriks.nl

metallic and semi-metallic gaskets:

- spiral wound
- ring type joint
- serrated
- insulating sets

flange gaskets and die-cut parts of:

- elastomers
- fibre sheet
- PTFE sheet/tape
- graphite sheet

stuffing-box packings
mechanical seals

DYNAMIC SEALS



T +31 72 514 18 55
E seals@eriks.nl

oil seals
Eri-sleeves shaft protecting
V-rings
PS seals
seals, guide parts and wipers for hydraulic and pneumatic cylinders
Multiseals
Omniseals[®] spring actuated
PTFE seals
end caps
KVSP Kalrez[®] valve stem packings
lubricants
greases
leak detection sprays
liquid sealants

O-RING & TECHNICAL RUBBER



T +31 72 514 18 66
E seals@eriks.nl

rubber moulded parts
profiles of:

- cellular rubber
- sponge rubber
- solid rubber

inflatable seals
O-rings
X-rings
back-up rings
cords
adhesives
boxes of assorted O-rings
vibration absorbers

GENERAL



T +31 72 514 15 14
E info@eriks.nl

Should you need a product you cannot find on this page, please call us on our general telephone number. We will be glad to help you further.

ERIKS

know-how makes the difference

V-rings

ERIKS bv
P.O. Boxs 280
1800 BK Alkmaar

T +31 72 514 15 14
F +31 72 515 56 45

info@eriks.nl
www.eriks.nl

Content

	Page
The sealing principle	3
The functioning	3
Basic profiles	3
Materials.	3
Applications	4
Counterface demands.	5
Roughness of the counterface.	5
RX [®] V-ring type A.	6
RX [®] V-ring type S.	9
RX [®] V-ring type L NBR.	11
RX [®] V-ring type E NBR.	12
Nomograph for the peripheral speed	14
Friction	15
Mounting the ERIKS V-ring	15

Liability

The information in this documentation is based on a long-year experience on the application of sealing elements. In spite of this experience, in some cases undefined parameters can limit the theoretical tasks considerably. In such cases therefore we cannot give any guarantees for the accuracy of our recommendations. We request you to consult us in case any extraordinary demands are put to the product. Dimensions and images can be changed at any moment when new experiences become available. All rights related to this documentation are reserved by ERIKS. No prints or copies of this documentation can be used without the explicit approval of ERIKS.

V-rings

The sealing principle

An "ERIKS V-seal" is an all rubber one-piece seal which is mounted on a shaft and seals axially against a counterface. Normally the seal rotates with the shaft.

The construction of the ERIKS V-seal is divided into 3 parts:

- a the body; the body of the V-seal which clamps itself on the shaft;
- b the conical self-adjusting lip;
- c the hinge

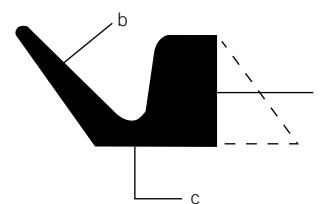

Fig. 1

The functioning

Through its elastic fit the ERIKS V-ring clamps itself in position by on the shaft and rotates with the shaft. Because of this, the static sealing between the shaft and the V-ring is ensured. The flexible sealing lip contacts the counterface - settles tolerances and deviations - herewith producing the dynamic sealing. The functioning of an ERIKS V-seal serves two purposes: a dynamic sealing element as well as a flinger. Because of the peripheral speed, dirt and liquids are removed and will not attach to the sealing lip.

As the image shows the sealing lip prevents dirt and liquids from entering.

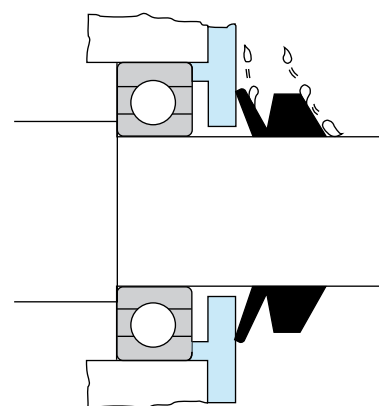

Fig. 2

Basic profiles

The ERIKS V-seal is manufactured in four standard profiles.

- Profiles type A and S are standard. The S type is delivered for shaft sizes up to 200 mm; the A type is for shaft sizes up to 2020 mm. The A type V-seal has a smaller mounting space.
- If the sealing house is limited or if the ERIKS V-seal makes part of a labyrinth sealing, often the L type is preferred.
- Type E is a special, rigid execution with a reinforced profile. This profile is used if more axial tolerances are required and is available in the ranges from 450 to 2010 mm.

Materials

NBR

For batch production the ERIKS V-rings is manufactured from a specially developed compound. This NBR compound is ozone resistant (tested according to DIN 53509 part 1) and can therefore be used in a wide range of applications.

Temperatuurbereik

-40 °C tot +100 °C

Media

Mineral oils, grease, water, acids

FPM/ Fluorrubber (Viton®)

For temperatures from - 20 °C up to +200 °C and against aggressive media FPM is used.

Other materials on request.

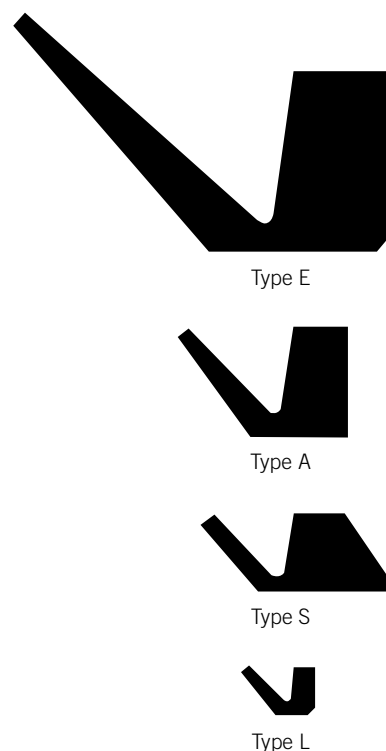

Fig. 3

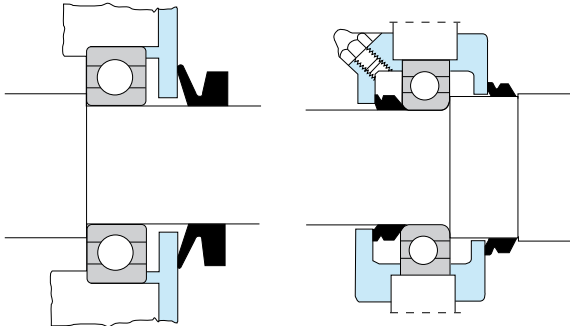

Fig. 4

Fig. 5

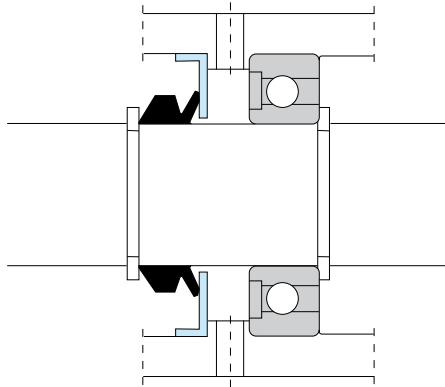

Fig. 6

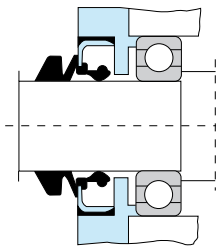

Fig. 7

Applications

ERIKS V-rings have certain technical advantages:

1. Low friction and therefore lower power losses related to the application of oil seals;
2. Long lifetime;
3. Simple construction; no seal housing is required;
4. The shafts do not need a special surface treatment;
5. Simple mounting;
6. No wear of the shaft;
7. Dual function: as a seal and as a flinger through which possible dirt and liquids are thrown away;
8. The flexible lip is unlikely to become damaged during storage and assembly;
9. An ERIKS V-ring is applicable for a wide range of shaft diameters. With 85 sizes you have access to an assortment of ERIKS V-seals for shaft sizes from 3 till 2000 mm (1/8" to 80");
10. Suitable for high RPM;
11. Misalignment of the shaft has no negative effect on the functioning of the V-seal;
12. Attractive pricing.

Where is the V-seal used?

The ERIKS V-ring is used as a pressureless sealing preventing dirt, water, oil splash and dust to enter the system.

The most familiar applications are:

Pumps, electro motors, paper machines, rolling mills, metal - and wood treatment devices, agricultural machines, etc.

Mounting examples and instructions

On mounting, the ERIKS V-ring can be stretched up to 200%. While mounting the V-ring no sharp tooling may be used. Shock vulcanized seals may not be stretched. Up to a peripheral speed of 7 to 8 m/s, ERIKS V-rings do not need any extra support. At higher speeds extra support of, for example, a tie-rip or clamping band can be necessary. Up to 12 m/s axial support is sufficient; for speeds from 12 to 15 m/s radial retention is required. With speeds over 15 m/s the lip will come off the counterface as a result of centrifugal force. The images show some of the constructive retention possibilities.

Counterface demands

The friction is heavily influenced by the peripheral speed as well as the surface. The surface does not need to be hardened and should be free from spiral formed twisted grooves. The roughness tolerances of the counterface are presented in the enclosed table.

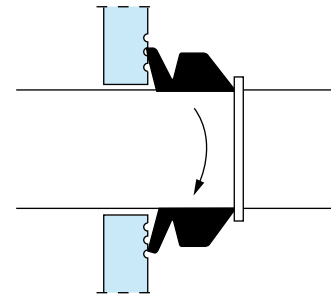

Fig. 8

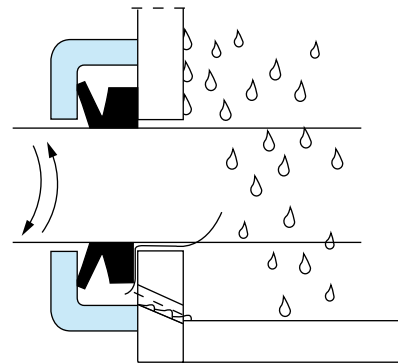

Fig. 9

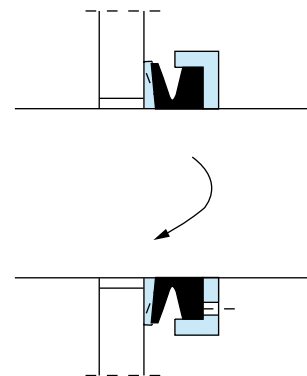

Fig. 10

Roughness of the counterface

Medium	Peripheral speed m/s	Counterface			
		Ra	Rt	CLA	RMS
Oil, water, dirt and grease	>10	0,4 - 0,8	1,7 - 6,4	16 - 32	17,6 - 38,4
Oil, water, dirt and grease	5-10	0,8 - 1,6	3,3 - 11,5	32 - 64	35,2 - 76,8
Polluted water, grease and dirt	1-5	1,6 - 2,0	6,4 - 14	64 - 80	70,4 - 96,0
Grease and dirt	<1	2,0	7,8 - 14	80	88,0 - 96,0



RX[®] V-ring type A

V-ring type S with bevel back serves as a pressure less, axial rod seal with a very short mounting length, which is clamped on a shaft. The flexible sealing lip seals a counterface at a right angle to the shaft preventing dirt, dust and splash to enter the construction.

Materiaal

Seal : NBR FPM
 Colour : zwart brown
 Hardness : 60° Shore A 60° Shore A

Operational circumstances

T : NBR: -40 till +100 °C/ FPM: -25 till +200 °C
 V : ≤ 8m/s, from 8 to 12 m/s radial support is recommended.
 With speeds over 15 m/s the lip will come off the counter face.

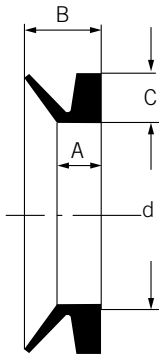

Counterface treatment

See table: surface roughness (page 5)

Sizes

see table

Mounting

The ERIKS V-ring must be mounted to the counterface respecting a recommended distance so the sealing lip gets the right tension.

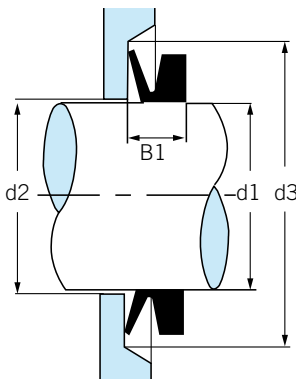

Fig. 11

V-ring type A								
V-ring type	Shaft diameter	ID	Profile height	Size	Profile width	Max.	Min.	Mounting width
	d1	d	c	A	B	d2	d3	B1
V-3A	2,7 - 3,5	2,5	1,5	2,1	3,0	d1 + 1	d1 + 4	2,5 ± 0,3
V-4A	3,5 - 4,5	3,2	2	2,4	3,7	d1 + 1	d1 + 6	3,0 ± 0,4
V-5A	4,5 - 5,5	4	2	2,4	3,7	d1 + 1	d1 + 6	3,0 ± 0,4
V-6A	5,5 - 6,5	5	2	2,4	3,7	d1 + 1	d1 + 6	3,0 ± 0,4
V-7A	6,5 - 8,0	6	2	2,4	3,7	d1 + 1	d1 + 6	3,0 ± 0,4
V-8A	8,0 - 9,5	7	2	2,4	3,7	d1 + 1	d1 + 6	3,0 ± 0,4
V-10A	9,5 - 11,5	9	3	3,4	5,5	d1 + 2	d1 + 9	4,5 ± 0,6
V-12A	11,5 - 12,5	10,5	3	3,4	5,5	d1 + 2	d1 + 9	4,5 ± 0,6
V-13A	12,5 - 13,5	11,7	3	3,4	5,5	d1 + 2	d1 + 9	4,5 ± 0,6
V-14A	13,5 - 15,5	12,5	3	3,4	5,5	d1 + 2	d1 + 9	4,5 ± 0,6
V-16A	15,5 - 17,5	14	3	3,4	5,5	d1 + 2	d1 + 9	4,5 ± 0,6
V-18A	17,5 - 19,0	16	3	3,4	5,5	d1 + 2	d1 + 12	6,0 ± 0,8
V-20A	19 - 21	18	4	4,7	7,5	d1 + 2	d1 + 12	6,0 ± 0,8
V-22A	21 - 24	20	4	4,7	7,5	d1 + 2	d1 + 12	6,0 ± 0,8
V-25A	24 - 27	22	4	4,7	7,5	d1 + 2	d1 + 12	6,0 ± 0,8
V-28A	27 - 29	25	4	4,7	7,5	d1 + 3	d1 + 12	6,0 ± 0,8
V-30A	29 - 31	27	4	4,7	7,5	d1 + 3	d1 + 12	6,0 ± 0,8
V-32A	31 - 33	29	4	4,7	7,5	d1 + 3	d1 + 12	6,0 ± 0,8
V-35A	33 - 36	31	4	4,7	7,5	d1 + 3	d1 + 12	6,0 ± 0,8

V-ring type A (continuation)

V-ring type	Shaft diameter	ID	Profile height	Size	Profile width	Max.	Min.	Mounting width
	d1	d	c	A	B	d2	d3	B1
V-38A	36 - 38	34	4	4,7	7,5	d1 + 3	d1 + 12	6,0 ± 0,8
V-40A	38 - 43	36	5	5,5	9,0	d1 + 3	d1 + 15	7,0 ± 1,0
V-45A	43 - 48	40	5	5,5	9,0	d1 + 3	d1 + 15	7,0 ± 1,0
V-50A	48 - 53	45	5	5,5	9,0	d1 + 3	d1 + 15	7,0 ± 1,0
V-55A	53 - 58	49	5	5,5	9,0	d1 + 3	d1 + 15	7,0 ± 1,0
V-60A	58 - 63	54	5	5,5	9,0	d1 + 3	d1 + 15	7,0 ± 1,0
V-65A	63 - 68	58	5	5,5	9,0	d1 + 3	d1 + 15	7,0 ± 1,0
V-70A	86 - 73	63	6	6,8	11,0	d1 + 4	d1 + 18	9,0 ± 1,2
V-75A	73 - 78	67	6	6,8	11,0	d1 + 4	d1 + 18	9,0 ± 1,2
V-80A	78 - 83	72	6	6,8	11,0	d1 + 4	d1 + 18	9,0 ± 1,2
V-85A	83 - 88	76	6	6,8	11,0	d1 + 4	d1 + 18	9,0 ± 1,2
V-90A	88 - 93	81	6	6,8	11,0	d1 + 4	d1 + 18	9,0 ± 1,2
V-95A	93 - 98	85	6	6,8	11,0	d1 + 4	d1 + 18	9,0 ± 1,2
V-100A	98 - 105	90	6	6,8	11,0	d1 + 4	d1 + 18	9,0 ± 1,2
V-110A	105 - 115	99	7	7,9	12,8	d1 + 4	d1 + 21	10,5 ± 1,5
V-120A	115 - 125	108	7	7,9	12,8	d1 + 4	d1 + 21	10,5 ± 1,5
V-130A	125 - 135	117	7	7,9	12,8	d1 + 4	d1 + 21	10,5 ± 1,5
V-140A	135 - 145	126	7	7,9	12,8	d1 + 4	d1 + 21	10,5 ± 1,5
V-150A	145 - 155	135	7	7,9	12,8	d1 + 4	d1 + 21	10,5 ± 1,5
V-160A	155 - 165	144	8	9,0	14,5	d1 + 5	d1 + 24	12,0 ± 1,8
V-170A	165 - 175	153	8	9,0	14,5	d1 + 5	d1 + 24	12,0 ± 1,8
V-180A	175 - 185	162	8	9,0	14,5	d1 + 5	d1 + 24	12,0 ± 1,8
V-190A	185 - 195	171	8	9,0	14,5	d1 + 5	d1 + 24	12,0 ± 1,8
V-199A	195 - 210	180	8	9,0	14,5	d1 + 5	d1 + 24	12,0 ± 1,8
V-200A	190 - 210	180	15	14,3	25,0	d1 + 10	d1 + 45	20,0 ± 4,0
V-220A	210 - 235	198	15	14,3	25,0	d1 + 10	d1 + 45	20,0 ± 4,0
V-250A	235 - 265	225	15	14,3	25,0	d1 + 10	d1 + 45	20,0 ± 4,0
V-275A	265 - 290	247	15	14,3	25,0	d1 + 10	d1 + 45	20,0 ± 4,0
V-300A	290 - 310	270	15	14,3	25,0	d1 + 10	d1 + 45	20,0 ± 4,0
V-325A	310 - 335	292	15	14,3	25,0	d1 + 10	d1 + 45	20,0 ± 4,0
V-350A	335 - 365	315	15	14,3	25,0	d1 + 10	d1 + 45	20,0 ± 4,0
V-375A	365 - 390	337	15	14,3	25,0	d1 + 10	d1 + 45	20,0 ± 4,0
V-400A	390 - 430	360	15	14,3	25,0	d1 + 10	d1 + 45	20,0 ± 4,0
V-450A	430 - 480	405	15	14,3	25,0	d1 + 10	d1 + 45	20,0 ± 4,0
V-500A	480 - 530	450	15	14,3	25,0	d1 + 10	d1 + 45	20,0 ± 4,0
V-550A	530 - 580	495	15	14,3	25,0	d1 + 10	d1 + 45	20,0 ± 4,0
V-600A	580 - 630	540	15	14,3	25,0	d1 + 10	d1 + 45	20,0 ± 4,0
V-650A	630 - 665	600	15	14,3	25,0	d1 + 10	d1 + 45	20,0 ± 4,0
V-700A	665 - 705	630	15	14,3	25,0	d1 + 10	d1 + 45	20,0 ± 4,0
V-725A	705 - 745	670	15	14,3	25,0	d1 + 10	d1 + 45	20,0 ± 4,0
V-750A	745 - 785	705	15	14,3	25,0	d1 + 10	d1 + 45	20,0 ± 4,0
V-800A	785 - 830	745	15	14,3	25,0	d1 + 10	d1 + 45	20,0 ± 4,0
V-850A	830 - 875	785	15	14,3	25,0	d1 + 10	d1 + 45	20,0 ± 4,0

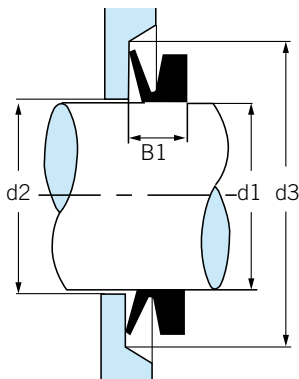
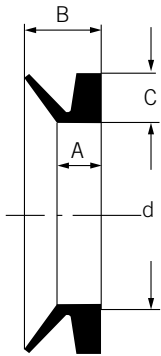

Fig. 12

V-ring type A (continuation)

V-ring type	Shaft diameter d1	ID d	Profile height c	Size A	Profile width B	Max. d2	Min. d3	Mounting width B1
V-900A	875 - 920	825	15	14,3	25,0	d1 + 10	d1 + 45	20,0 ± 4,0
V-950A	920 - 965	865	15	14,3	25,0	d1 + 10	d1 + 45	20,0 ± 4,0
V-1000A	965 - 1015	910	15	14,3	25,0	d1 + 10	d1 + 45	20,0 ± 4,0
V-1050A	1015 - 1065	955	15	14,3	25,0	d1 + 10	d1 + 45	20,0 ± 4,0
V-1100A	1065 - 1115	1000	15	14,3	25,0	d1 + 10	d1 + 45	20,0 ± 4,0
V-1150A	1115 - 1165	1045	15	14,3	25,0	d1 + 10	d1 + 45	20,0 ± 4,0
V-1200A	1165 - 1215	1090	15	14,3	25,0	d1 + 10	d1 + 45	20,0 ± 4,0
V-1250A	1215 - 1270	1135	15	14,3	25,0	d1 + 10	d1 + 45	20,0 ± 4,0
V-1300A	1270 - 1320	1180	15	14,3	25,0	d1 + 10	d1 + 45	20,0 ± 4,0
V-1350A	1320 - 1370	1225	15	14,3	25,0	d1 + 10	d1 + 45	20,0 ± 4,0
V-1400A	1370 - 1420	1270	15	14,3	25,0	d1 + 10	d1 + 45	20,0 ± 4,0
V-1450A	1420 - 1470	1315	15	14,3	25,0	d1 + 10	d1 + 45	20,0 ± 4,0
V-1500A	1470 - 1520	1360	15	14,3	25,0	d1 + 10	d1 + 45	20,0 ± 4,0
V-1550A	1520 - 1570	1405	15	14,3	25,0	d1 + 10	d1 + 45	20,0 ± 4,0
V-1600A	1570 - 1620	1450	15	14,3	25,0	d1 + 10	d1 + 45	20,0 ± 4,0
V-1650A	1620 - 1670	1495	15	14,3	25,0	d1 + 10	d1 + 45	20,0 ± 4,0
V-1700A	1670 - 1720	1540	15	14,3	25,0	d1 + 10	d1 + 45	20,0 ± 4,0
V-1750A	1720 - 1770	1585	15	14,3	25,0	d1 + 10	d1 + 45	20,0 ± 4,0
V-1800A	1770 - 1820	1630	15	14,3	25,0	d1 + 10	d1 + 45	20,0 ± 4,0
V-1850A	1820 - 1870	1675	15	14,3	25,0	d1 + 10	d1 + 45	20,0 ± 4,0
V-1900A	1870 - 1920	1720	15	14,3	25,0	d1 + 10	d1 + 45	20,0 ± 4,0
V-1950A	1920 - 1970	1765	15	14,3	25,0	d1 + 10	d1 + 45	20,0 ± 4,0
V-2000A	1970 - 2020	1810	15	14,3	25,0	d1 + 10	d1 + 45	20,0 ± 4,0



RX[®] V-ring type S

V-ring type S with bevel back serves as a pressureless, axial rod seal which is clamped on a shaft. The flexible sealing lip seals a counterface at a right angle to the shaft, preventing dirt, dust and splash to enter the construction.

Materiaal

Seal : NBR FPM
 Colour : zwart black
 Hardness : 60° Shore A 60° Shore A

Operational circumstances

T : NBR: -40 till +100 °C/ FPM: -25 till +200 °C
 V : ≤ 8m/s, from 8 to 12 m/s radial support is recommended.
 With speeds over 15 m/s the lip will come off the counterface.

Counterface treatment

See table: surface roughness (page 5)

Sizes

see table

Mounting

The ERIKS V-ring must be mounted to the counterface, respecting a recommended distance so the sealing lip gets the right tension.

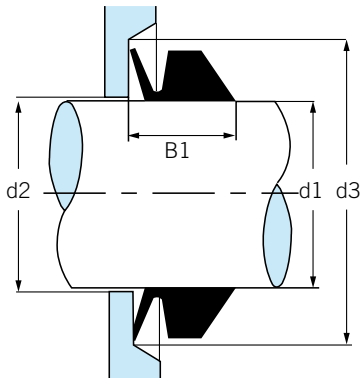
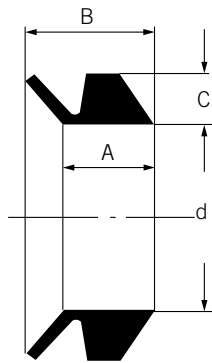

Fig. 13

V-ring type S

V-ring type	Shaft diameter d1	ID d	Profile height c	Size A	Profile width B	Max. d2	Min. d3	Mounting width B1
V-5S	4,5 - 5,5	4	2	3,9	5,2	d1+ 1	d1+ 6	4,5±0,4
V-6S	5,5 - 6,5	5	2	3,9	5,2	d1+ 1	d1+ 6	4,5±0,4
V-7S	6,5 - 8,0	6	2	3,9	5,2	d1+ 1	d1+ 6	4,5±0,4
V-8S	8,0 - 9,5	7	2	3,9	5,2	d1+ 1	d1+ 6	4,5±0,4
V-10S	9,5 - 11,5	9	3	5,6	7,7	d1+ 2	d1+ 9	6,7±0,6
V-12S	11,5 - 13,5	10,5	3	5,6	7,7	d1+ 2	d1+ 9	6,7±0,6
V-14S	13,5 - 15,5	12,5	3	5,6	7,7	d1+ 2	d1+ 9	6,7±0,6
V-16S	15,5 - 17,5	14	3	5,6	7,7	d1+ 2	d1+ 9	6,7±0,6
V-18S	17,5 - 19,0	16	3	5,6	7,7	d1+ 2	d1+ 9	6,7±0,6
V-20S	19 - 21	18	4	7,9	10,5	d1+ 2	d1+12	9,0±0,8
V-22S	21 - 24	20	4	7,9	10,5	d1+ 2	d1+12	9,0±0,8
V-25S	24 - 27	22	4	7,9	10,5	d1+ 2	d1+12	9,0±0,8
V-28S	27 - 29	25	4	7,9	10,5	d1+ 3	d1+12	9,0±0,8
V-30S	29 - 31	27	4	7,9	10,5	d1+ 3	d1+12	9,0±0,8
V-32S	31 - 33	29	4	7,9	10,5	d1+ 3	d1+12	9,0±0,8
V-35S	33 - 36	31	4	7,9	10,5	d1+ 3	d1+12	9,0±0,8
V-38S	36 - 38	34	4	7,9	10,5	d1+ 3	d1+12	9,0±0,8
V-40S	38 - 43	36	5	9,5	13,0	d1+ 3	d1+15	11,0±1,0
V-45S	43 - 48	40	5	9,5	13,0	d1+ 3	d1+15	11,0±1,0
V-50S	48 - 53	45	5	9,5	13,0	d1+ 3	d1+15	11,0±1,0
V-55S	53 - 58	49	5	9,5	13,0	d1+ 3	d1+15	11,0±1,0

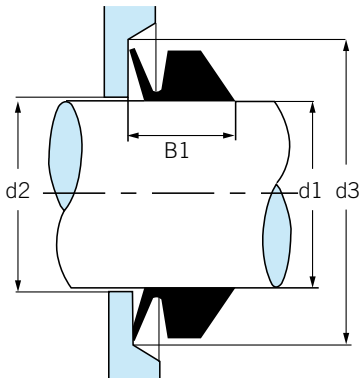
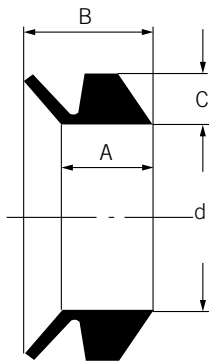

Fig. 14

V-ring type S (continuation)

V-ring type	Shaft diameter	ID	Profile height	Size	Profile width	Max.	Min.	Mounting width
	d1	d	c	A	B	d2	d3	B1
V-60S	58 - 63	54	5	9,5	13,0	d1+ 3	d1+15	11,0±1,0
V-65S	63 - 68	58	5	9,5	13,0	d1+ 3	d1+15	11,0±1,0
V-70S	68 - 73	63	6	11,3	15,5	d1+ 4	d1+18	13,5±1,2
V-75S	73 - 78	67	6	11,3	15,5	d1+ 4	d1+18	13,5±1,2
V-80S	78 - 83	72	6	11,3	15,5	d1+ 4	d1+18	13,5±1,2
V-85S	83 - 88	76	6	11,3	15,5	d1+ 4	d1+18	13,5±1,2
V-90S	88 - 93	81	6	11,3	15,5	d1+ 4	d1+18	13,5±1,2
V-95S	93 - 98	85	6	11,3	15,5	d1+ 4	d1+18	13,5±1,2
V-100S	98 - 105	90	6	11,3	15,5	d1+ 4	d1+18	13,5±1,2
V-110S	105 - 115	99	7	13,1	18,0	d1+ 4	d1+21	15,5±1,5
V-120S	115 - 125	108	7	13,1	18,0	d1+ 4	d1+21	15,5±1,5
V-130S	125 - 135	117	7	13,1	18,0	d1+ 4	d1+21	15,5±1,5
V-140S	135 - 145	126	7	13,1	18,0	d1+ 4	d1+21	15,5±1,5
V-150S	145 - 155	135	7	13,1	18,0	d1+ 4	d1+21	15,5±1,5
V-160S	155 - 165	144	8	15,0	20,5	d1+ 5	d1+24	18,0±1,8
V-170S	165 - 175	153	8	15,0	20,5	d1+ 5	d1+24	18,0±1,8
V-180S	175 - 185	162	8	15,0	20,5	d1+ 5	d1+24	18,0±1,8
V-190S	185 - 195	171	8	15,0	20,5	d1+ 5	d1+24	18,0±1,8
V-199S	195 - 210	180	8	15,0	20,5	d1+ 5	d1+24	18,0±1,8



RX[®] V-ring type L NBR

V-ring type L with straight back serves as a pressureless axial rod seal with a very small mounting length, which is clamped on the shaft. The flexible sealing lip seals a counterface at a right angle to the shaft preventing dirt, dust and splash to enter the construction.

Material

Seal : NBR
 Colour : black
 Hardness : 60° Shore A

Operational circumstances

T : -40 till +100 °C
 V : ≤ 8m/s, from 8 to 12 m/s radial support is recommended.
 With speeds over 15 m/s the lip will come off the counter face.

Counter face treatment

See table: surface roughness (page 5)

Sizes

see table

Mounting

The ERIKS V-ring must be mounted to the counterface, respecting a recommended distance so the sealing lip gets the right tension

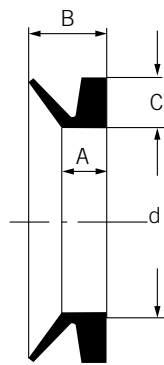

B = 10,5 mm
 A = 6 mm
 C = 6,5 mm

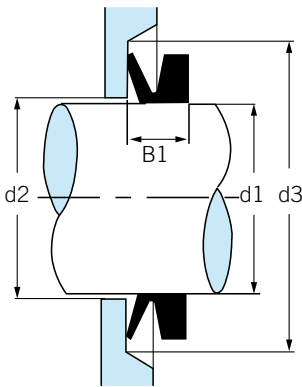

B1 = 8,5 ± 1,5 mm
 d2max = d1 + 5 mm
 d3min = d1 + 20 mm

Fig. 15

V-ring type L NBR

V-ring type	Shaft diameter d1	ID d
V - 140L	135 - 145	126
V - 150L	145 - 155	135
V - 160L	155 - 165	144
V - 170L	165 - 175	153
V - 180L	175 - 185	162
V - 190L	185 - 195	171
V - 200L	195 - 210	182
V - 220L	210 - 233	198
V - 250L	233 - 260	225
V - 275L	260 - 285	247
V - 300L	285 - 310	270
V - 325L	310 - 335	292
V - 350L	335 - 365	315
V - 375L	365 - 385	337
V - 400L	385 - 410	360
V - 425L	410 - 440	382
V - 450L	440 - 475	405



RX[®] V-ring type E NBR

V-ring type E with straight back serves as a pressureless axial rod seal with a very small mounting length, which is clamped on the shaft.

The flexible sealing lip seals a counter face at a right angle to the shaft preventing dirt, dust and splash to enter the construction. The type E is designed for heavy use or is applied in situations where larger axial tolerances are required. This profile is delivered for shafts from Ø450 to Ø2010 mm.

Material

Seal : NBR FPM
 Colour : black brown
 Hardness : 60° Shore A

Operational circumstances

T : NBR: -30 till +100 °C/ FPM: -15 till +200 °C
 V : ≤ 8m/s, from 8 to 12 m/s radial support is recommended.
 With speeds over 15 m/s , the lip will come off the counter face.

Counter face treatment

See table: surface roughness (page 5)

Sizes

see table

Mounting

The ERIKS V-ring must be mounted to the counterface, respecting a recommended distance so the sealing lip gets the right tension de afdichtingslip de juiste voorspanning krijgt.

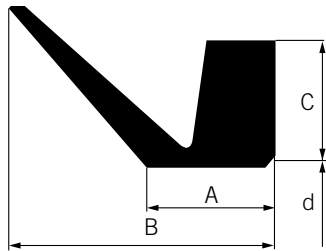

B = 32,5 mm
 A = 65 mm
 C = 30 mm

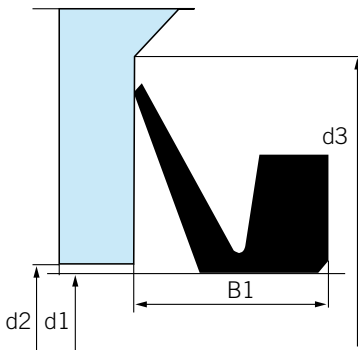

B1 = 50 ± 12 mm
 d2max = d1 + 24 mm
 d3min = d1 + 110 mm

Fig. 16

V-ring type E NBR			V-ring type E NBR (continuation)		
V-ring type	Shaft diameter	ID diameter	V-ring type	Shaft diameter	ID diameter
	d1	d		d1	d
V - 450E	450 - 455	439	V - 545E	545 - 550	531
V - 455E	455 - 460	444	V - 550E	550 - 555	536
V - 460E	460 - 465	448	V - 555E	555 - 560	541
V - 465E	465 - 470	453	V - 560E	560 - 565	546
V - 470E	470 - 475	458	V - 565E	565 - 570	550
V - 475E	475 - 480	463	V - 570E	570 - 575	555
V - 480E	480 - 485	468	V - 575E	575 - 580	560
V - 485E	485 - 490	473	V - 580E	580 - 585	565
V - 490E	490 - 495	478	V - 585E	585 - 590	570
V - 495E	495 - 500	483	V - 590E	590 - 600	575
V - 500E	500 - 505	488	V - 600E	600 - 610	582
V - 505E	505 - 510	493	V - 610E	610 - 620	592
V - 510E	510 - 515	497	V - 620E	620 - 630	602
V - 515E	515 - 520	502	V - 630E	630 - 640	612
V - 520E	520 - 525	507	V - 640E	640 - 650	621
V - 525E	525 - 530	512	V - 650E	650 - 660	631
V - 530E	530 - 535	517	V - 660E	660 - 670	640
V - 535E	535 - 540	521	V - 670E	670 - 680	650
V - 540E	540 - 545	526	V - 680E	680 - 690	660

V-rings

V-ring type E NBR (continuation)		
V-ring type	Shaft diameter	ID
	d1	diameter
	d1	d
V - 690E	690 - 700	670
V - 700E	700 - 710	680
V - 710E	710 - 720	689
V - 720E	720 - 730	699
V - 730E	730 - 740	709
V - 740E	740 - 750	718
V - 750E	750 - 758	728
V - 760E	758 - 766	735
V - 770E	766 - 774	743
V - 780E	774 - 783	751
V - 790E	783 - 792	759
V - 800E	792 - 801	768
V - 810E	801 - 810	777
V - 820E	810 - 821	786
V - 830E	821 - 831	796
V - 840E	831 - 841	805
V - 850E	841 - 851	814
V - 860E	851 - 861	824
V - 870E	861 - 871	833
V - 880E	871 - 882	843
V - 890E	882 - 892	853
V - 900E	892 - 912	871
V - 920E	912 - 922	880
V - 930E	922 - 933	890
V - 940E	933 - 944	900
V - 950E	944 - 955	911
V - 960E	955 - 966	921
V - 970E	966 - 977	932
V - 980E	977 - 988	942
V - 990E	988 - 999	953
V - 1000E	999 - 1010	963
V - 1020E	1010 - 1025	973
V - 1040E	1025 - 1045	990
V - 1060E	1045 - 1065	1008
V - 1080E	1065 - 1085	1027
V - 1100E	1085 - 1105	1045
V - 1120E	1105 - 1125	1065
V - 1140E	1125 - 1145	1084
V - 1160E	1145 - 1165	1103
V - 1180E	1165 - 1185	1121

V-ring type E NBR (continuation)		
V-ring type	Shaft diameter	ID
	d1	diameter
	d1	d
V - 1200E	1185 - 1205	1139
V - 1220E	1205 - 1225	1157
V - 1240E	1225 - 1245	1176
V - 1260E	1245 - 1270	1195
V - 1280E	1270 - 1295	1218
V - 1300E	1295 - 1315	1240
V - 1325E	1315 - 1340	1259
V - 1350E	1340 - 1365	1281
V - 1375E	1365 - 1390	1305
V - 1400E	1390 - 1415	1328
V - 1425E	1415 - 1440	1350
V - 1450E	1440 - 1465	1374
V - 1475E	1465 - 1490	1397
V - 1500E	1490 - 1515	1419
V - 1525E	1515 - 1540	1443
V - 1550E	1540 - 1570	1467
V - 1575E	1570 - 1600	1495
V - 1600E	1600 - 1640	1524
V - 1650E	1640 - 1680	1559
V - 1700E	1680 - 1720	1596
V - 1750E	1720 - 1765	1632
V - 1800E	1765 - 1810	1671
V - 1850E	1810 - 1855	1714
V - 1900E	1855 - 1905	1753
V - 1950E	1905 - 1955	1794
V - 2000E	1955 - 2010	1844

Nomograph for the peripheral speed

With the help of the table shown below, based on the diameter and the RPM the peripheral speed can be determined. Example given: with a diameter of 30 mm and 3000 RPM the peripheral speed is about 5 m/s.

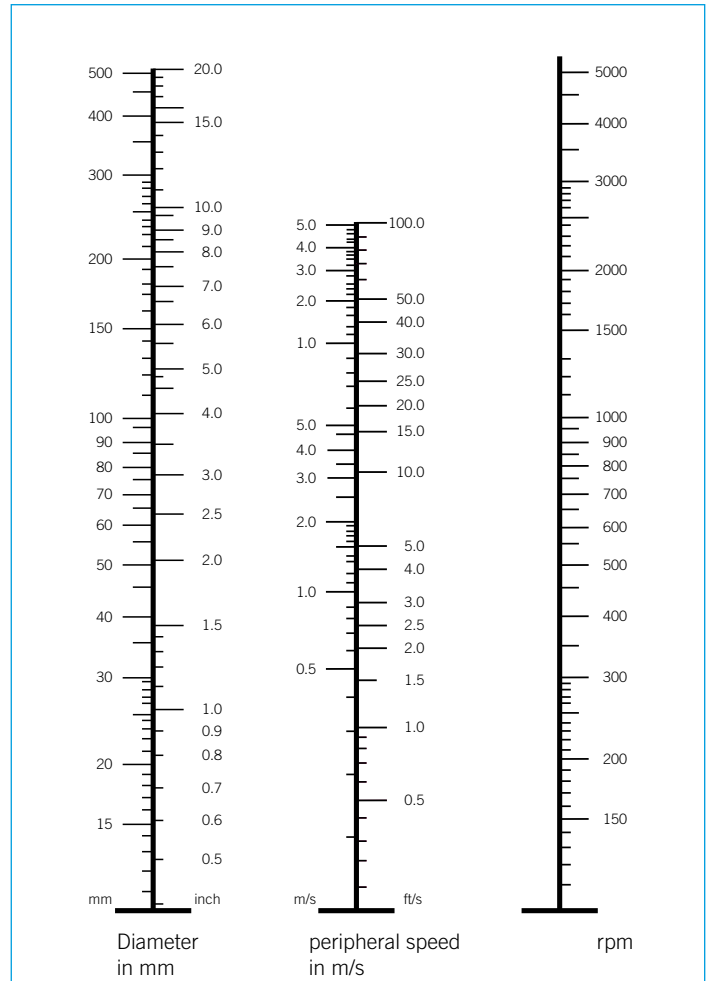
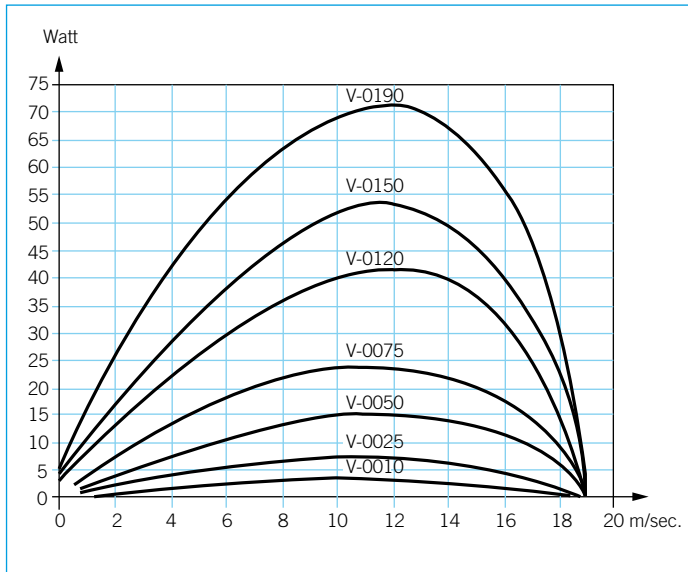

Fig. 17



Above schedule gives an impression on the power used. For AF or Surfapplus coated ERIKS V-rings this power will be reduced considerably.

Fig. 18

Friction

The friction depends on:

1. The rubber compound
Especially the special AF (Anti Friction) compound gives a low specific friction up to 50% reduction depending on the RPM. However, availability is limited. For this reason ERIKS developed a coating that limits the friction to an absolute minimum! Please ask for the Surfapplus coated ERIKS V-ring.
2. The peripheral speed.
Up to a speed of 12 m/s friction increases. Over 12 m/s the friction decreases under influence of the centrifugal force.
3. Tension.
If the tension on the sealing lip is too high friction increases. Always mount the ERIKS V-ring with the right mounting width.
4. Lubrication
The presence of oil or grease positively influences the friction.
5. The diameter of the ERIKS V-ring
An ERIKS V-ring with a large diameter gives more friction than an ERIKS V-ring with a small diameter

Mounting the ERIKS V-ring

The mounting is very simple. The ERIKS V-ring can be stretched up to 200% and be moved over the shaft. The ERIKS V-ring is positioned towards the counterface by a blunt object. For serial mountings it is easier to make use of special tooling: some kind of cap that moves over the shaft and directly places the ring in the right position.

Installation

In certain situations it is technically impossible to mount the ERIKS V-ring. In these situations the ERIKS V-ring can be cut and be made endless again. Changing the ERIKS V-ring to an endless version can be done in two ways:

- with use of cyanoacrylate instant glue (glued version);
- vulcanized by using special equipment.

Glued version

In case the ERIKS V-ring is glued together, it is to be noted that:

- the temperature range does not exceed +70 °C
- the glue resists to the media used.

ERIKS Europe

ERIKS bv

Toermalijnstraat 5
1812 RL Alkmaar
The Netherlands
Postbus 280
1800 BK Alkmaar
The Netherlands
T +31 (0)72 514 15 14
F +31 (0)72 515 56 45
E info@eriks.nl
website www.eriks.nl

ERIKS nv

Boombekelaan 3
Hoboken 2660
Belgium
T +32 (0) 3.829.2611
F +32 (0) 3.828.3959
E info@eriks.be
www.eriks.be

ERIKS Sealing Technolgy UK

Unit 5
Yorks Park
Dudley
West Midlands
T U.K. +44 (0)121 508 6008
F +44 (0)121 508 6009
E tradeline@eriks.co.uk
www.eriks.co.uk

Pioneer Weston

206 Cavendish Place
WA3 6WU Birchwood Park
Warrington, Cheshire
United Kingdom
T +44 1925 853 000
F +44 1925 853 030
E info@pwi-ltd.com
www.eriks.co.uk

ERIKS GmbH Division Dichtungstechnik

Brönninghauser Straße 38
33729 Bielefeld
Germany
T +49 (0) 521 / 9399-0
F +49 (0) 521 / 9399-49
E dichtungstechnik@eriks.de
www.eriks.de

Passerotti sp. z o.o.

ul. Spoldzielcow 94A
43 - 303 Bielsko - Biala
Poland
T + 48 33 499 77 00
F + 48 33 499 77 17
E marketing@passerotti.com
www.passerotti.pl

ERIKS sas

52, Avenue des Frères-Lumière
78190 Trappes
France
B.P. 151
78196 Trappes-Cédex
T France +33 (0) 13.482.1000
F +33 (0) 13.482.1020
E info@eriks.fr
www.eriks.fr

ERIKS s.r.o Bratislava

Rožnavská 1
831 04 Bratislava
Slovakia
T +421 (0)2 4437 2895
F +421 (0)2 4437 2899
E info@eriks.sk
www.eriks.sk

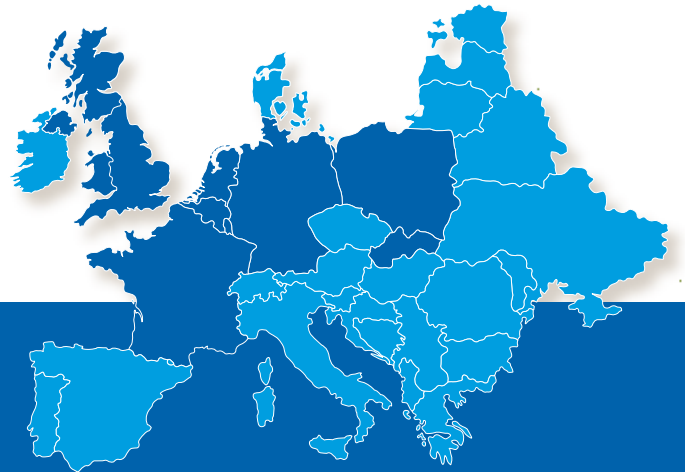

www.eriks.com
www.eriks.info

know-how makes the difference

ERIKS